

THIS DOCUMENT CONTAINS DATA PROPRIETARY TO PROJECTS UNLIMITED, INC. ANY USE OR REPRODUCTION, IN ANY FORM, WITHOUT PRIOR WRITTEN PERMISSION OF PROJECTS UNLIMITED, INC. IS PROHIBITED.  
© 2005, Projects Unlimited Inc.

### SPECIFICATIONS

PARAMETERS	VALUES	UNITS
RATED VOLTAGE	10	Vp-p
OPERATING VOLTAGE RANGE	1 ~ 30	Vp-p
RATED CURRENT (MAX)	3.5	mA
CAPACITANCE	13000±30%	pF
MINIMUM SPL @ 10 CM	88	dBA
RESONANT FREQUENCY	3000±500	Hz
OPERATING TEMPERATURE	-20 ~ +60	°C
STORAGE TEMPERATURE	-30 ~ +70	°C
HOUSING MATERIAL	ABS	-
TERMINAL MATERIAL	Sn PLATED PHOSPHER BRONZE	-
WEIGHT	2	grams

REVISIONS			
LTR	DESCRIPTION	DATE	APPROVED
-	RELEASED FROM ENGINEERING	5/9/06	

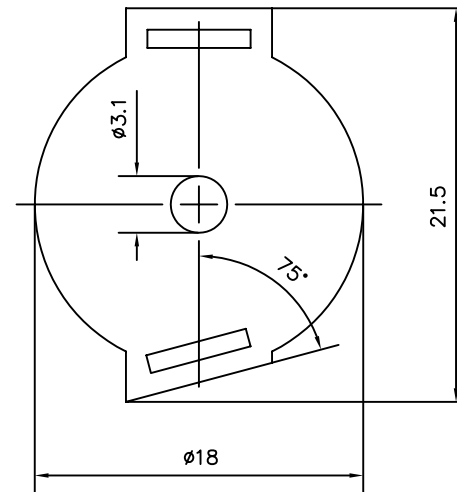
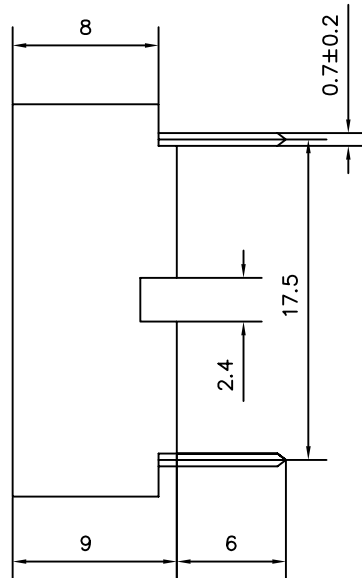

**NOTES:**

1. ALL DIMENSIONS ARE IN MILLIMETERS.
2. SPECIFICATION SUBJECT TO CHANGE OR WITHDRAWAL WITHOUT NOTICE.
3. THIS PART IS RoHS 2002/95/EC COMPLIANT.

FILE NAME  
AT-1830-TT-R.DWG

UNLESS OTHERWISE SPECIFIED: DIMENSIONS ARE IN MILLIMETERS, TOLERANCES ARE ±0.5 AND ANGLES ARE ±3°.		 projects® unlimited Dayton, Ohio	
APPROVALS	DATE	TRANSDUCER (PIEZO)  DRAWING NO. AT-1830-TT-R	
DRAWN <i>J.D.</i>	5/06		
CHECKED <i>B.R.</i>	5/06		
APPROVED <i>B.R.</i>	5/06		
DO NOT SCALE DRAWING		SIZE A	SHEET 1 OF 1 SCALE: N.T.S.